

Specifications

MEASUREMENTS	Metric	US
Working height	6.47 m	20 ft 8 in
Platform height	4.47 m	14 ft 8 in
A B Platform dimensions (l x w)		
Standard	0.89 x 0.75 m	35 x 29.5 in
Standard with extension	1.40 x 0.75 m	55 x 29.5 in
C Height - stowed	1.74	5 ft 7 in
D Length - stowed	1.35	4 ft 5 in
E Width	0.75 m	2 ft 5.5 in
F Ground clearance - centre	0.06 m	2.5 in

PRODUCTIVITY		
Lift capacity	227 kg	500 lbs
Lift capacity - extension deck	113 kg	250 lbs
Drive speed - stowed	4.0 km/h	2.5 mph
Drive speed - raised	0.8 km/h	0.5 mph
Gradeability	30%	30%
Turning radius - inside	zero	zero
- outside	1.42 m	4 ft 7 in
Raise/lower speed	21/19 sec	21/19 sec
Controls	24V DC proportional	
Tyres - solid non-marking	25 x 8 x 20 cm	10 x 3 x 8 in

POWER		
Power source	24 V (four 6 V 225 Ah batteries)	
Hydraulic system capacity	8.33 L	2.2 gal

WEIGHT		
	1025 kg	2,149 lbs

STANDARDS COMPLIANCE	ANSI A92.6, CSA B354.2, CE Compliance, AS 1418.10
----------------------	---

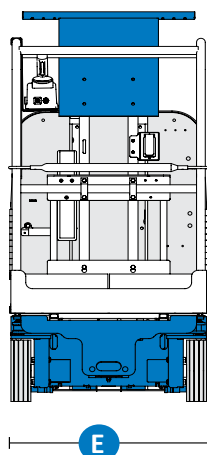
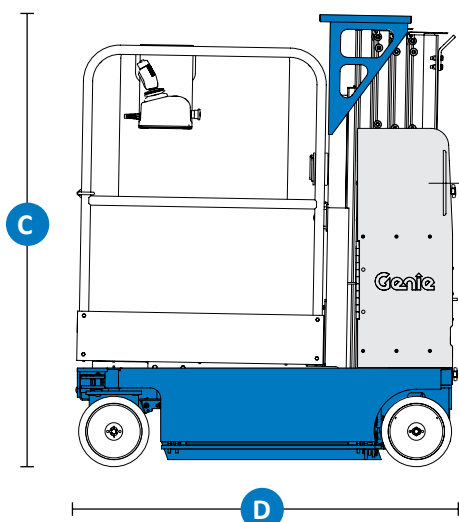
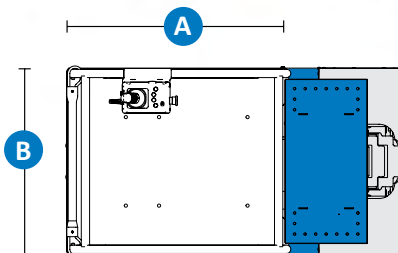

F

STANDARD FEATURES

PRODUCTIVITY

- Extension platform with sliding mid-rail
- Work station tray
- Auxiliary platform lowering
- Low 0.39 m (15.5 in) platform entry height
- Patented rigid mast system
- Fully proportional lift and drive controls
- Battery charge indicator
- Onboard diagnostic system
- Tilt alarm
- Zero inside turning radius
- Dual wheel brakes
- Hydraulic brake release
- Pothole protection
- Hinged rear ABS covers for easy access to all major electrical and hydraulic components
- Tie down attachment points
- Overhead crane attachment point
- Large forklift pockets access
- Non-marking solid tyres
- Dual flashing beacons
- Motion alarm
- Automotive horn
- Descent alarm

POWER

- Automatic 25 amp battery charger